



Underwater LED Lighting Installation Instructions

What you will need:

- Scissors
- Low stick masking tape
- Power drill (18V cordless preferred)
- 7/64" (#7 screw) or 9/64" (#8 screw) diameter drill bit
- 3/8" and 5/8" diameter drill bits
- Rubbing alcohol
- Clean cloth or paper towel
- Sealant (100% silicone) DO NOT USE 5200

These Underwater LED'S utilize state-of-the-art high powdered LED technology combined with a rugged military grade design to bring you the best value in underwater lighting. Our lights are manufactured in the USA and are inspected to meet the highest standards of quality.

The following steps are recommended to properly install your SCM-10v2. Avoiding proper installation procedures may void your warranty.

1. Choose mounting location: The lights require cooling and should be installed on a flat surface area that is frequently submerged, splashed, or sprayed. Also consider the area inside the boat where the wires will enter and make sure it will be accessible to retrieve the wire. It IS recommended to mount the light as low as possible for optimal water penetration and cooling. It IS NOT recommended to mount the lights on the bottom of the hull because it will create drag and increase the risk of damage to the light due to grounding or being struck by floating debris.
2. Cut out the provided template and tape in place on the boat surface. Make sure you are drilling into a place where you can get to the hole in order to feed wire. Make center drill location with pencil. Remove template and store in a safe place.
3. Drill a 7/64" (#7 screw) or a 9/64" (#8 screw) diameter hole in the center hole only, shown on template. TO AVOID CRACKING THE GEL GOAT TURN THE DRILL BACKWARDS!
4. If mounting to an aluminum hull use the optional foam gasket or spacer.

5. OPTION 1: At center hole use 3/8" diameter bit all the way through. Use 5/8" counter sink and drill 1" deep. Then run wire.

OPTION 2: At center hole use 5/8" all the way through. Then run wire.

6. Pour alcohol on a clean cloth and wipe the hull to remove dirt or wax.

7. Feed the wire though the hull.

8. Place a sufficient amount of silicone or 3M 4200 marine sealant on the hull around all three holes to seal them against the light's base plate.

9. Fill the screw holes with sealant.

10. Use provided screws (qty 2) to mount light to the hull.

Install Wiring

1. Route wire through the boat in a manor such that it is tied up out of standing water and protected from excessive heat or abrasion.

2. Route wire to a switch rated at a minimum of 5 amps per lights (i.e. for two lights: 5 amps x 2 lights=10 amps minimum switch rating). Switch is not provided.

3. Red wire = switched and fused 12+

4. Black wire = ground

5. Blue wire = PWM (Pulse Width Modulation) control wire. This wire is used to control strobing and dimming functions integrating into the light.

- *Contact Livorsi Marine to purchase a compatible controller or dimmer.*

6. Reversing the polarity will void your warranty.

7. The lights must be wired through a fuse or circuit breaker. FAILURE TO DO SO COULD CAUSE A FIRE AND INJURY OR DEATH.

8. Each light will require 4 amps at 12 volts.

SCM-4 Installation Diagram

LIT-LED-UWL-4610-INST

REV A

ECO 28610

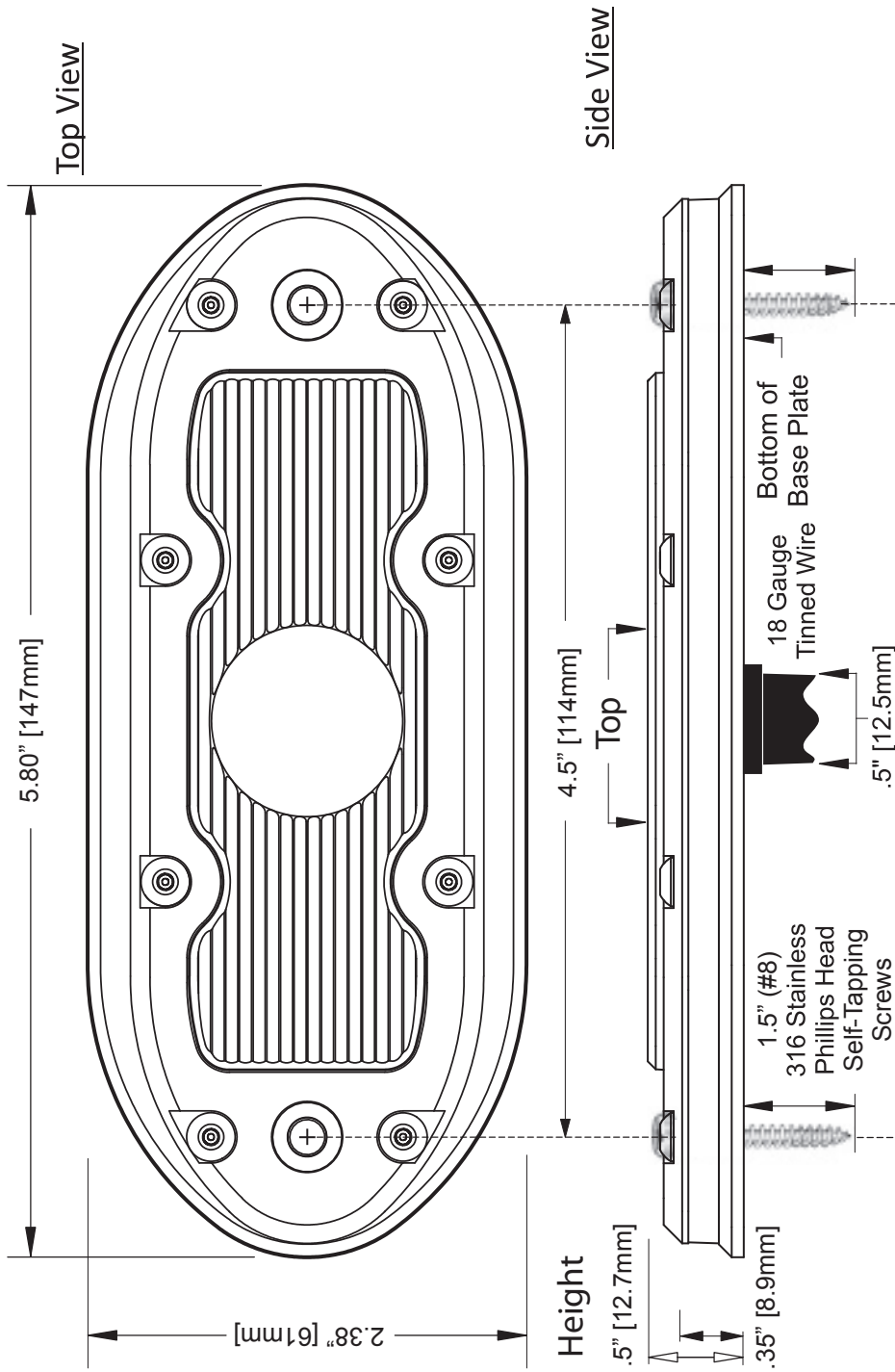

DO NOT USE TEMPLATE TO MARK SCREW HOLES

WHEN PRE-DRILLING SCREW HOLES WITH DRILL BIT OR PENCIL WHILE USING ACTUAL LIGHT HOUSING

DO NOT USE TEMPLATE TO MARK SCREW HOLES

WHEN PRE-DRILLING SCREW HOLES WITH DRILL BIT OR PENCIL WHILE USING ACTUAL LIGHT HOUSING

PLEASE READ INSTRUCTIONS INSIDE TEMPLATE

FOR CENTER WIRE HOLE USE THE FOLLOWING:

- 1st - DRILL PILOT HOLE AT CENTER FOR THE WIRE, THEN USE 5/8" DRILL THE WAY THROUGH
- 2nd - RUN WIRE THROUGH THE HOLE AND MARK ONE MOUNTING HOLE LOCATION
- 3rd - FOLLOW STEPS ON FRONT OF SHEET FOR DRILLING MOUNTING HOLES

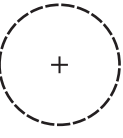

SCM-4™
Typical Power Requirements
1.4 Amps@12v

TAPE HERE

DO NOT USE TEMPLATE TO MARK SCREW HOLES

Scale 1:1 (if in doubt ask)

WHEN PRE-DRILLING SCREWS: FIRST PRE-DRILL CENTER HOLE AND RUN WIRE. THEN MARK YOUR SCREW HOLES WITH DRILL BIT OR PENCIL WHILE USING ACTUAL LIGHT HOUSING

TAPE HERE

SCM-6 Installation Diagram

LIT-LED-UWL-4610-INST

REV A

ECO 28610

Top View

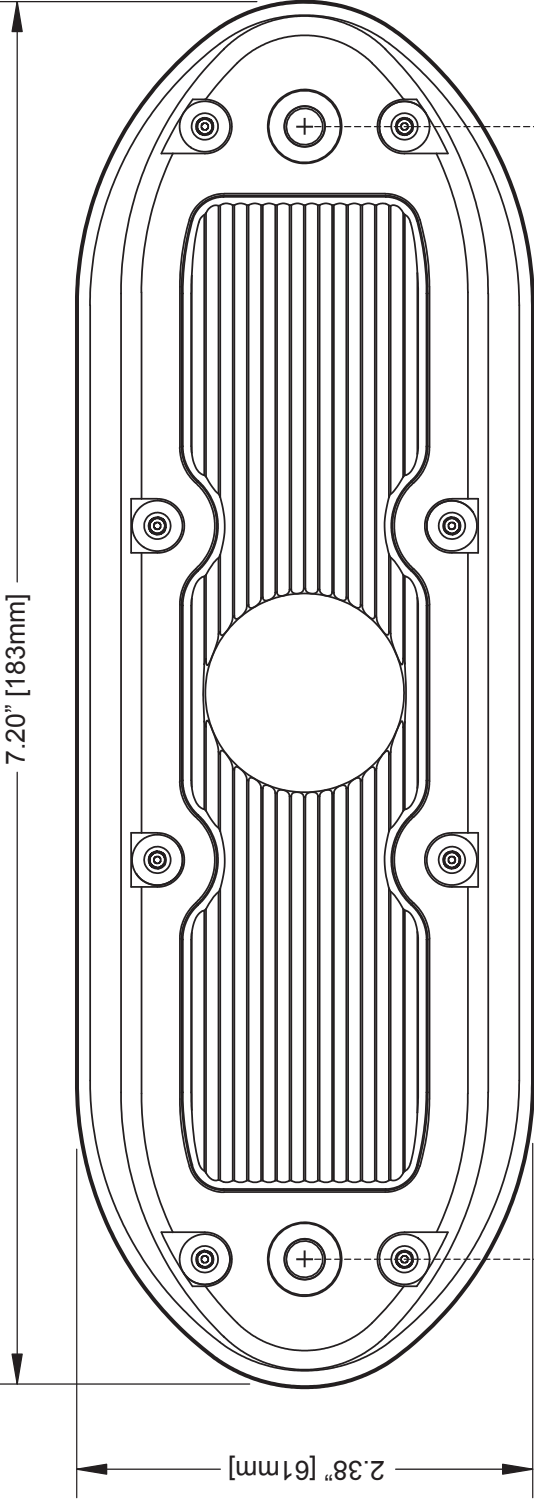

Side View

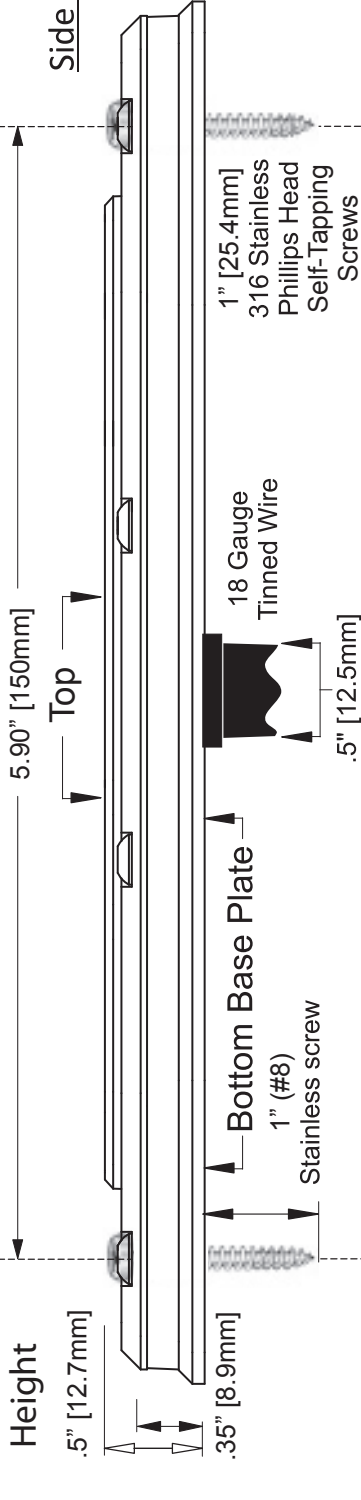

TAPE
HERE

PLEASE READ INSTRUCTIONS INSIDE TEMPLATE

FOR CENTER WIRE HOLE USE THE FOLLOWING:

1st - DRILL PILOT HOLE AT CENTER FOR THE WIRE, THEN USE 5/8" DRILL ALL THE WAY THROUGH

DO NOT USE TEMPLATE TO MARK SCREW HOLES

Scale 1:1 (If in doubt ask)

WHEN PRE-DRILLING SCREWS:

FIRST PRE-DRILL CENTER HOLE AND RUN WIRE. THEN MARK YOUR SCREW HOLES WITH DRILL BIT OR PENCIL WHILE USING ACTUAL LIGHT HOUSING

DO NOT USE TEMPLATE TO MARK SCREW HOLES

WHEN PRE-DRILLING SCREWS:

FIRST PRE-DRILL CENTER HOLE AND RUN WIRE. THEN MARK YOUR SCREW HOLES WITH DRILL BIT OR PENCIL WHILE USING ACTUAL LIGHT HOUSING

SCM-6TM

Typical Power Requirements

2.1 Amps@12v

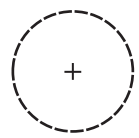

2nd - RUN WIRE THROUGH THE HOLE AND MARK ONE MOUNTING HOLE LOCATION

3rd - FOLLOW STEPS ON FRONT OF SHEET FOR DRILLING MOUNTING HOLES

TAPE
HERE

TAPE
HERE

SCM-10 Installation Diagram

LIT-LED-UWL-4610-INST

REV A

ECO 28610

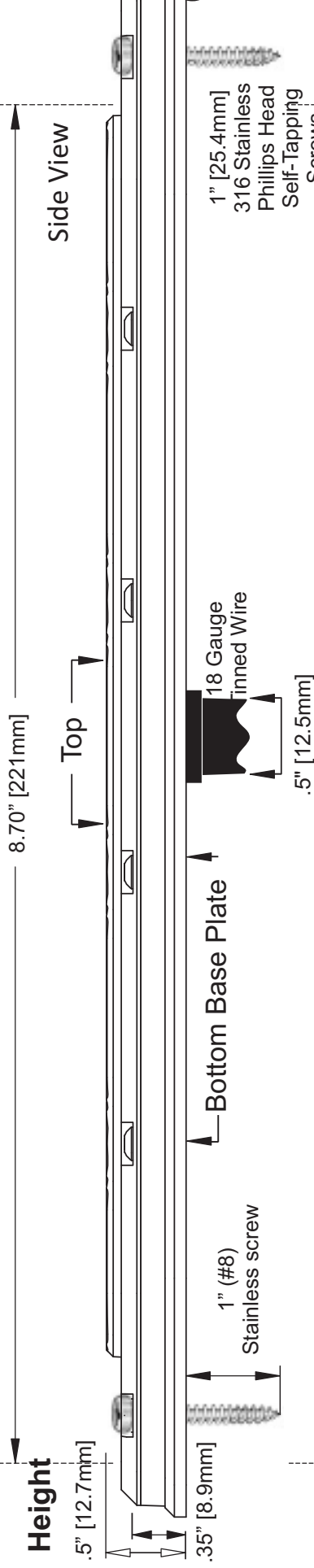
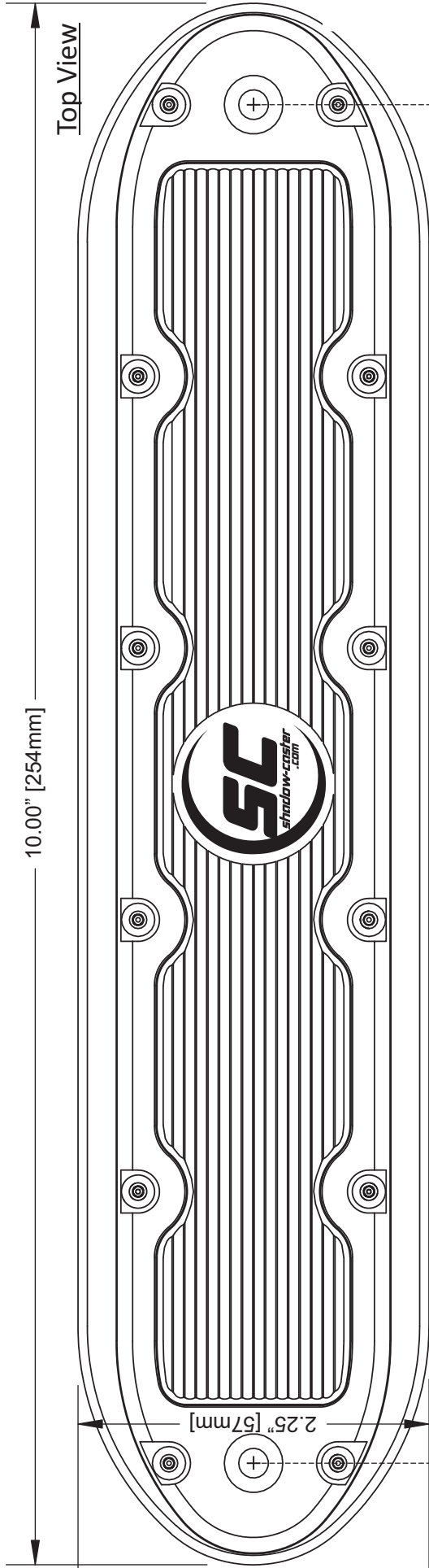

PLEASE READ INSTRUCTIONS INSIDE TEMPLATE

FOR CENTER WIRE HOLE USE THE FOLLOWING:

DO NOT USE TEMPLATE TO MARK SCREW HOLES

- 1st - DRILL PILOT HOLE AT CENTER FOR THE WIRE, THEN USE 5/8" DRILL ALL THE WAY THROUGH
- 2nd - RUN WIRE THROUGH THE HOLE AND MARK ONE MOUNTING HOLE LOCATION
- 3rd - FOLLOW STEPS ON FRONT OF SHEET FOR DRILLING MOUNTING HOLES

WHEN PRE-DRILLING SCREWS:
 FIRST PRE-DRILL CENTER HOLE AND RUN WIRE. THEN MARK YOUR SCREW HOLES WITH DRILL BIT OR PENCIL WHILE USING ACTUAL LIGHT HOUSING

SCM-10™
Typical Power Requirements
3.5 Amps@12v

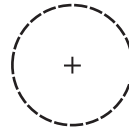

DO NOT USE TEMPLATE TO MARK SCREW HOLES

WHEN PRE-DRILLING SCREWS:
 FIRST PRE-DRILL CENTER HOLE AND RUN WIRE. THEN MARK YOUR SCREW HOLES WITH DRILL BIT OR PENCIL WHILE USING ACTUAL LIGHT HOUSING

Scale 1:1 (If in doubt ask)

TAPE HERE

TAPE HERE

TAPE HERE

TAPE HERE